

# 19. Exploded View and Replacement Parts List

## 19.1 Water System

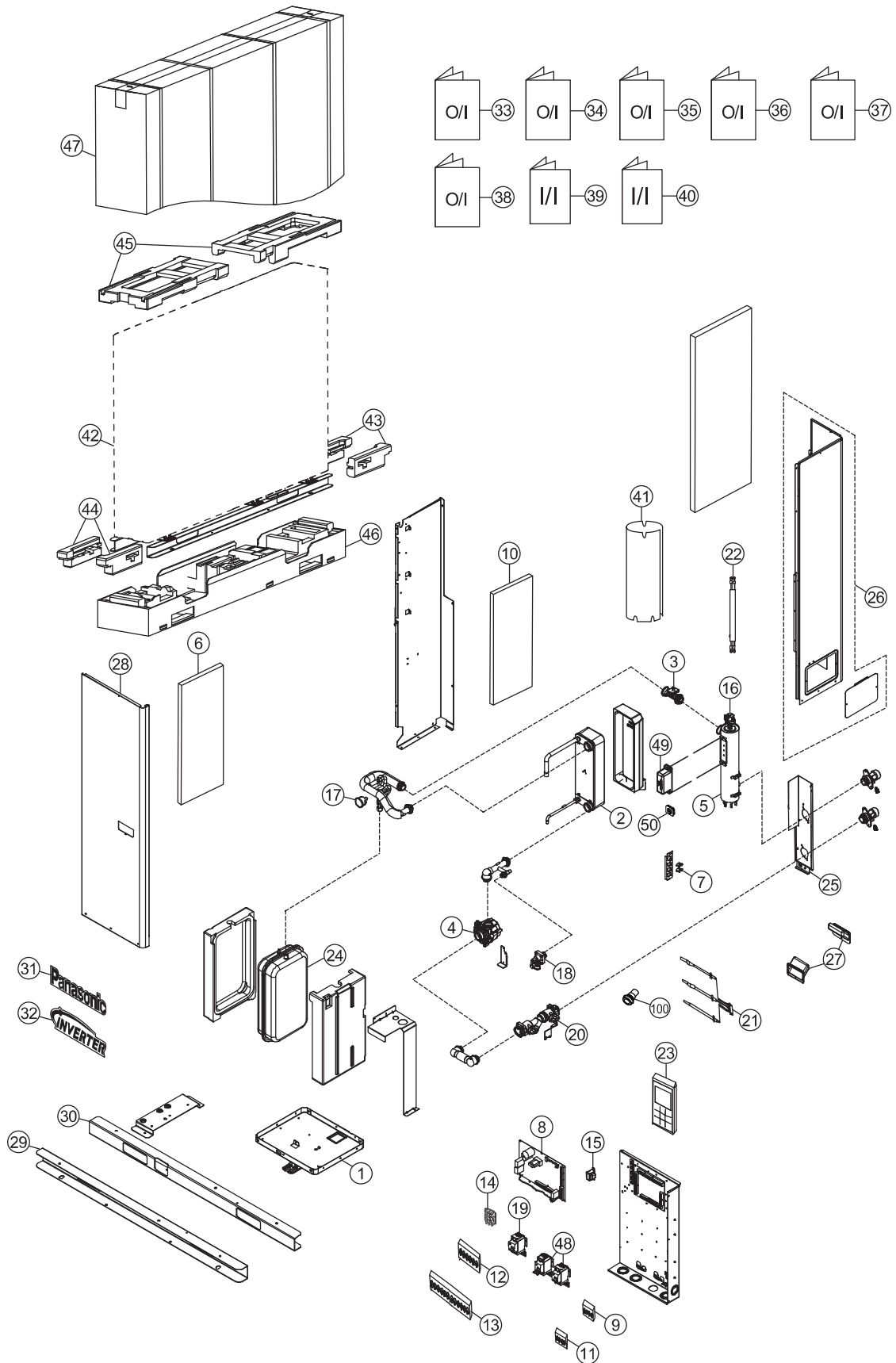

Note:  
 The above exploded view is for the purpose of parts disassembly and replacement.  
 The non-numbered parts are not kept as standard service parts.

## 19.2 Refrigerant System

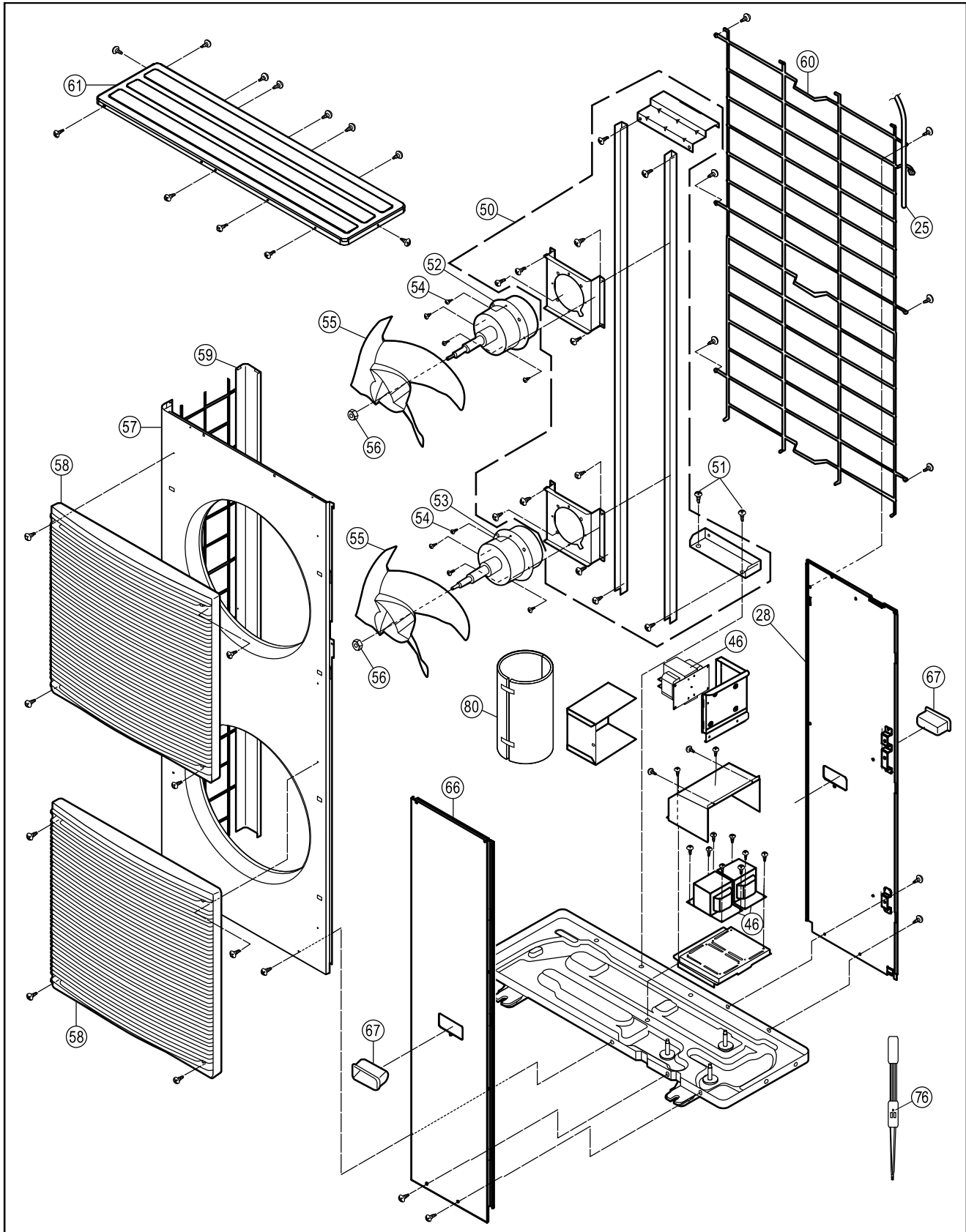

Note:  
The above exploded view is for the purpose of parts disassembly and replacement.  
The non-numbered parts are not kept as standard service parts.

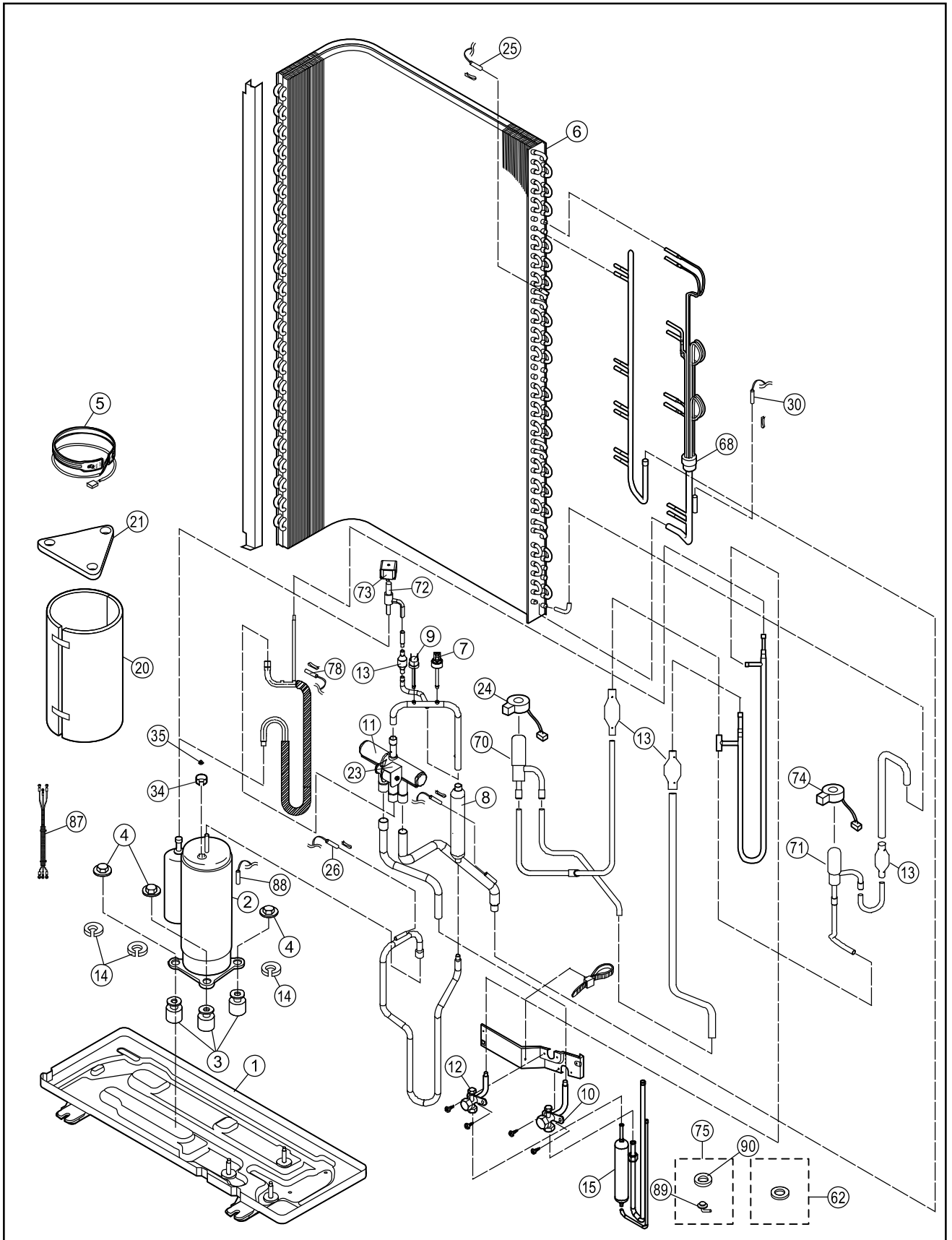

Note:  
 The above exploded view is for the purpose of parts disassembly and replacement.  
 The non-numbered parts are not kept as standard service parts.

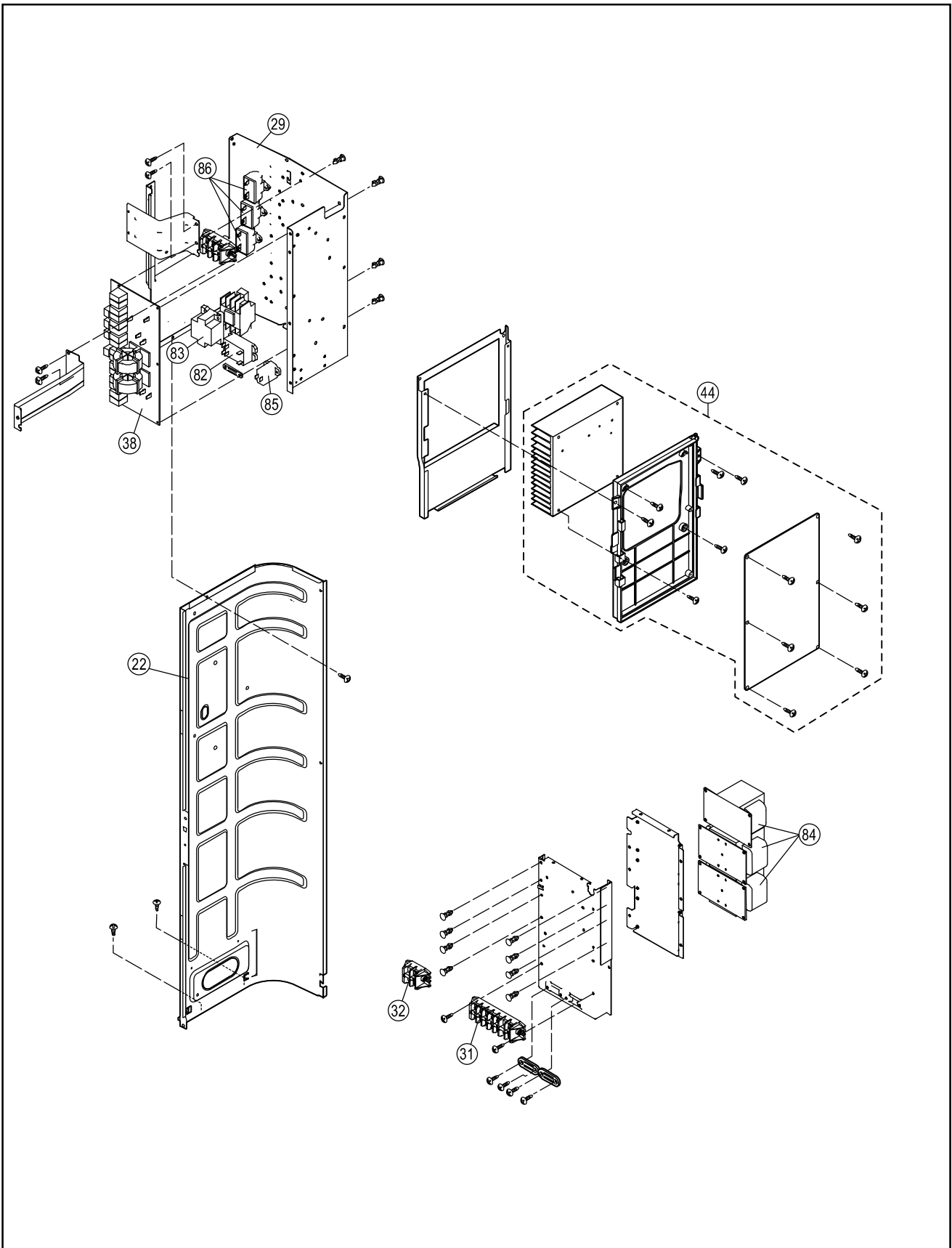

Note:  
 The above exploded view is for the purpose of parts disassembly and replacement.  
 The non-numbered parts are not kept as standard service parts.

<Water System>

SAFETY	REF. NO.	DESCRIPTION & NAME	QTY.	WH-MXC09H3E8	REMARK
	1	BASE PAN ASS'Y	1	ACXD52K02760	
	2	HOT WATER COIL-COMplete	1	ACXB90C00620	O
	3	FLOW SWITCH	1	CWB621137	O
	4	PUMP	1	CWB532116	O
	5	HEATER ASS'Y	1	ACXA34K00380	O
	6	SOUND PROOF MATERIAL	1	CWG302594	
⚠	7	THERMOSTAT	4	CWA151074	O
⚠	8	ELECTRONIC CONTROLLER (MAIN)	1	ACXA73C40130R	O
⚠	9	TERMINAL BOARD ASS'Y(A,B)	1	CWA28K1340	O
	10	SOUND PROOF MATERIAL	1	CWG302599	
⚠	11	TERMINAL BOARD ASS'Y(1,2,3,4,5,6)	1	CWA28K1341	O
⚠	12	TERMINAL BOARD ASS'Y(7,8,9,10,11,12)	1	CWA28K1340	O
⚠	13	TERMINAL BOARD ASS'Y(13,14,15,16,17,18)	1	CWA28K1343	O
⚠	14	TERMINAL BOARD ASS'Y ( A ) / (A,B)	1	CWA28K1260	O
⚠	15	REACTOR	1	G0C103Z00003	O
	16	AIR PURGE VALVE	1	ACXB62-00130	O
	17	PRESSURE GAUGE	1	CWB070003	O
	18	PRESSURE RELIEF VALVE	1	ACXB62-00100	O
	19	CIRCUIT BREAKER	1	CWA181005	O
	20	FILTER COMPLETE	1	CWB51C1021	
	21	SENSOR-COMplete(WATER IN,OUT, REF TEMP)	1	ACXA50C13330	O
	22	SENSOR-COMplete(HEX WATER OUTLET)	1	ACXA50C13140	O
	23	REMOTE CONTROL COMPLETE	1	CWA75C4681	O
	24	RECEIVER	1	CWB141039	
	25	HOLDER COUPLING	1	ACXH35-01510A	
	26	CABINET SIDE PLATE ASS'Y	1	ACXE04-09480A	
	27	HANDLE	2	CWE161014	
	28	CABINET FRONT PLATE	1	ACXE06-03550A	
	29	CONNECTING BAR	1	CWE261313A	
	30	CONNECTING BAR	1	CWE261214A	
	31	PANASONIC BADGE	1	CWE373439	
	32	INVERTER BADGE	1	CWE373441	
	33	OPERATING INSTRUCTION	1	ACXF55-14590	
	34	OPERATING INSTRUCTION	1	ACXF55-14600	
	35	OPERATING INSTRUCTION	1	ACXF55-14610	
	36	OPERATING INSTRUCTION	1	ACXF55-14620	
	37	OPERATING INSTRUCTION	1	ACXF55-14630	
	38	OPERATING INSTRUCTION	1	ACXF55-14640	
	39	INSTALLATION INSTRUCTION	1	ACXF60-30020	
	40	INSTALLATION INSTRUCTION	1	ACXF60-17020	
	41	SOUND PROOF MATERIAL	1	ACXG30-07660	
	42	BAG	1	CWG861452	
	43	SHOCK ABSORBER	1	CWG713241	
	44	SHOCK ABSORBER	1	CWG713242	
	45	SHOCK ABSORBER	1	CWG713243	

SAFETY	REF. NO.	DESCRIPTION & NAME	QTY.	WH-MXC09H3E8	REMARK
	46	BASE BOARD-COMPLETE	1	CWG62C1132	
	47	C.C.CASE	1	CWG568053	
	48	CIRCUIT BREAKER	1	CWA181008	O
	49	TERMINAL COVER	1	CWH171051	
	50	GASKET FOR TERMINAL COVER	1	CWB811177	
	100	FILTER COMPLETE	1	ACXB51-00080	

**Note:**

- All parts are supplied from PAPAMY, Malaysia (Vendor Code: 00029488).
- "O" marked parts are recommended to be kept in stock.

SAFETY	REF. NO.	DESCRIPTION & NAME	QTY.	WH-MXC12H9E8	WH-MXC16H9E8	REMARK
	1	BASE PAN ASS'Y	1	ACXD52K02760	←	
	2	HOT WATER COIL-COMplete	1	ACXB90C00620	ACXB90C00730	O
	3	FLOW SWITCH	1	CWB621137	←	O
	4	PUMP	1	CWB532116	←	O
	5	HEATER ASS'Y	1	ACXA34K00390	←	O
	6	SOUND PROOF MATERIAL	1	CWG302594	←	
⚠	7	THERMOSTAT	4	CWA151074	←	O
⚠	8	ELECTRONIC CONTROLLER (MAIN)	1	ACXA73C40140R	ACXA73C40150R	O
⚠	9	TERMINAL BOARD ASS'Y(A,B)	1	CWA28K1340	←	O
	10	SOUND PROOF MATERIAL	1	CWG302599	←	
⚠	11	TERMINAL BOARD ASS'Y(1,2,3,4,5,6)	1	CWA28K1341	←	O
⚠	12	TERMINAL BOARD ASS'Y(7,8,9,10,11,12)	1	CWA28K1340	←	O
⚠	13	TERMINAL BOARD ASS'Y(13,14,15,16,17,18)	1	CWA28K1343	←	O
⚠	14	TERMINAL BOARD ASS'Y ( A ) / (A,B)	1	CWA28K1238	←	O
⚠	15	REACTOR	1	G0C103Z00003	←	O
	16	AIR PURGE VALVE	1	ACXB62-00130	←	O
	17	PRESSURE GAUGE	1	CWB070003	←	O
	18	PRESSURE RELIEF VALVE	1	ACXB62-00100	←	O
	20	FILTER COMPLETE	1	CWB51C1021	←	
	21	SENSOR-COMplete(WATER IN,OUT, REF TEMP)	1	ACXA50C13330	←	O
	22	SENSOR-COMplete(HEX WATER OUTLET)	1	ACXA50C13140	←	O
	23	REMOTE CONTROL COMPLETE	1	CWA75C4681	←	O
	24	RECEIVER	1	CWB141039	←	
	25	HOLDER COUPLING	1	ACXH35-01510A	←	
	26	CABINET SIDE PLATE ASS'Y	1	ACXE04-09480A	←	
	27	HANDLE	2	CWE161014	←	
	28	CABINET FRONT PLATE	1	ACXE06-03550A	←	
	29	CONNECTING BAR	1	CWE261313A	←	
	30	CONNECTING BAR	1	CWE261214A	←	
	31	PANASONIC BADGE	1	CWE373439	←	
	32	INVERTER BADGE	1	CWE373441	←	
	33	OPERATING INSTRUCTION	1	ACXF55-14590	←	
	34	OPERATING INSTRUCTION	1	ACXF55-14600	←	
	35	OPERATING INSTRUCTION	1	ACXF55-14610	←	
	36	OPERATING INSTRUCTION	1	ACXF55-14620	←	
	37	OPERATING INSTRUCTION	1	ACXF55-14630	←	
	38	OPERATING INSTRUCTION	1	ACXF55-14640	←	
	39	INSTALLATION INSTRUCTION	1	ACXF60-30020	←	
	40	INSTALLATION INSTRUCTION	1	ACXF60-17020	←	
	41	SOUND PROOF MATERIAL	1	ACXG30-07660	←	
	42	BAG	1	CWG861452	←	
	43	SHOCK ABSORBER	1	CWG713241	←	
	44	SHOCK ABSORBER	1	CWG713242	←	
	45	SHOCK ABSORBER	1	CWG713243	←	
	46	BASE BOARD-COMplete	1	CWG62C1132	←	
	47	C.C.CASE	1	CWG568053	←	

SAFETY	REF. NO.	DESCRIPTION & NAME	QTY.	WH-MXC12H9E8	WH-MXC16H9E8	REMARK
	48	CIRCUIT BREAKER	2	CWA181008	←	O
	49	TERMINAL COVER	1	CWH171051	←	
	50	GASKET FOR TERMINAL COVER	1	CWB811177	←	
	100	FILTER COMPLETE	1	ACXB51-00080	←	



**Note:**

- All parts are supplied from PAPAMY, Malaysia (Vendor Code: 00029488).
- "O" marked parts are recommended to be kept in stock.



<Refrigerant System>



SAFETY	REF. NO.	DESCRIPTION & NAME	QTY.	WH-MXC09H3E8	WH-MXC12H9E8	REMARK
	1	BASE PAN ASS'Y	1	CWD52K1276	←	
	2	COMPRESSOR	1	5JD420XBA22	←	O
	3	BUSHING - COMPRESSOR MOUNT	3	CWH50055	←	
	4	NUT-COMPRESSOR MOUNT	3	CWH561049	←	
	5	CRANKCASE HEATER	1	ACXA34-00110	←	
	6	CONDENSER COMPLETE	1	CWB32C3891	←	
	7	HIGH PRESSURE SENSOR	1	CWA501463	←	O
	8	DISCHARGE MUFFLER	1	CWB121014	←	
	9	HIGH PRESSURE SWITCH	1	CWA101013	←	O
	10	3-WAYS VALVE (GAS)	1	CWB011699	←	O
	11	4-WAYS VALVE	1	CWB001046	←	O
	12	3-WAYS VALVE(LIQUID)	1	CWB011700	←	O
	13	STRAINER	4	CWB111032	←	
	14	GASKET FOR TERMINAL COVER	3	CWB811017	←	
	15	RECEIVER	1	CWB141069	←	
	20	SOUND PROOF MATERIAL - COMP. BODY	1	ACXG30-00850	←	
	21	SOUND PROOF MATERIAL - COMP. TOP	1	CWG302266	←	
	22	SOUND PROOF BOARD	1	CWH151243	←	
	23	V-COIL COMPLETE(4 WAY VALVE)	1	CWA43C2169J	←	O
	24	V-COIL COMPLETE(MAIN EXPANSION VALVE)	1	CWA43C2602	←	O
	25	SENSOR-COMP.(OUTDOOR AIR,PIPE TEMP)	1	CWA50C2730	←	O
	26	SENSOR-COMP.(DISCHARGE TEMP)	1	CWA50C2576	←	O
	28	CABINET REAR PLATE-COMPLETE	1	ACXE02-02020A	←	
	29	CONTROL BOARD CASING	1	CWH10K1049	←	
	30	SENSOR-COMP.(DEFROST TEMP)	1	CWA50C2577	←	O
	31	TERMINAL BOARD ASS'Y(1,2,3,4,5)	1	CWA28K1240	←	O
	34	TERMINAL COVER	1	CWH171039A	←	
	35	NUT - TERMINAL COVER	1	CWH7080300J	←	
	38	ELECTRONIC CO.(NOISE FILTER)	1	CWA747838	←	O
	44	ELECTRONIC CONTROLLER (MAIN)	1	ACXA73C40840R	ACXA73C40850R	O
	46	REACTOR - MAIN	3	G0C293J00001	←	O
	50	FAN MOTOR BRACKET	1	CWD54K1084	←	
	51	SCREW-FAN MOTOR BRACKET	2	CWH551040J	←	
	52	FAN MOTOR(UPPER)	1	EHDS83LAC	←	O
	53	FAN MOTOR(LOWER)	1	EHDS83MAC	←	O
	54	SCREW-FAN MOTOR MOUNT	8	CWH551323	←	
	55	PROPELLER FAN ASSY	2	CWH00K1006	←	
	56	NUT	2	CWH561092	←	
	57	CABINET FRONT PLATE	1	CWE061098A	←	
	58	DISCHARGE GRILLE	2	CWE201073	←	O
	59	CABINET SIDE PLATE ASSY	1	CWE04K1023A	←	
	60	WIRE NET	1	CWD041069	←	
	61	CABINET TOP PLATE	1	CWE03C1105	←	
	62	ACCESSORY CO.(RUBBER CAP)	1	CWH82C1839	←	
	66	CABINET FRONT PLATE	1	CWE061274A	←	
	67	HANDLE	2	CWE161014	←	

SAFETY	REF. NO.	DESCRIPTION & NAME	QTY.	WH-MXC09H3E8	WH-MXC12H9E8	REMARK
	68	TUBE ASSY (CAP.TUBE)	1	CWT07K1606	←	
	70	EXPANSION VALVE (1)	1	CWB051049	←	O
	71	EXPANSION VALVE (2)	1	CWB051029	←	
	72	2-WAYS VALVE(LIQUID)	1	CWB021637	←	O
	73	V-COIL COMPLETE(2-WAY VALVE)	1	CWA43C2607	←	O
	74	V-COIL COMPLETE(BYPASS EXPANSION VALVE)	1	CWA43C2335	←	O
	75	ACCESSORY CO.(DRAIN ELBOW)	1	CWG87C900	←	
	76	HEATER	1	CWA341071	←	O
	78	SENSOR COMPLETE (BYPASS & EVA EXIT TEMP)	1	CWA50C3165	←	O
	80	SOUND PROOF MATERIAL	1	CWG302598	←	
	82	ELECTRO MAGNETIC SWITCH	1	K6C2AGA00002	←	O
	83	ELECTRO MAGNETIC SWITCH	1	K6C4E8A00001	←	O
	84	REACTOR - SUB	3	G0C153J00009	←	O
	85	PTC THERMISTORS	1	D4DDG1010001	←	O
	86	CAPACITOR	3	DS441205NPQA	←	O
	87	LEADWIRE COMPRESSOR	1	CWA67C9411	←	
	88	SENSOR-COMPLETE (CN-TANK)	1	CWA50C2629	←	
	89	FLEXIBLE PIPE (L-TUBE)	1	CWH5850080	←	
	90	PACKING-L.TUBE	1	CWB81012	←	

**Note:**

- All parts are supplied from PAPAMY, Malaysia (Vendor Code: 00029488).
- "O" marked parts are recommended to be kept in stock.

SAFETY	REF. NO.	DESCRIPTION & NAME	QTY.	WH-MXC16H9E8	REMARK
	1	BASE PAN ASS'Y	1	CWD52K1276	
	2	COMPRESSOR	1	5JD650XBA22	O
	3	BUSHING - COMPRESSOR MOUNT	3	CWH50055	
	4	NUT-COMPRESSOR MOUNT	3	CWH561049	
	5	CRANKCASE HEATER	1	ACXA34-00110	
	6	CONDENSER COMPLETE	1	ACXB32C0001	
	7	HIGH PRESSURE SENSOR	1	CWA501463	O
	8	DISCHARGE MUFFLER	1	CWB121014	
	9	HIGH PRESSURE SWITCH	1	CWA101013	O
	10	3-WAYS VALVE (GAS)	1	CWB011699	O
	11	4-WAYS VALVE	1	CWB001046	O
	12	3-WAYS VALVE(LIQUID)	1	CWB011700	O
	13	STRAINER	4	CWB111032	
	14	GASKET FOR TERMINAL COVER	3	CWB811017	
	15	RECEIVER	1	CWB141069	
	20	SOUND PROOF MATERIAL - COMP. BODY	1	CWG302795	
	21	SOUND PROOF MATERIAL - COMP. TOP	1	CWG302266	
	22	SOUND PROOF BOARD	1	CWH151243	
	23	V-COIL COMPLETE(4 WAY VALVE)	1	CWA43C2169J	O
	24	V-COIL COMPLETE(MAIN EXPANSION VALVE)	1	CWA43C2602	O
	25	SENSOR-COMP.(OUTDOOR AIR,PIPE TEMP)	1	CWA50C2730	O
	26	SENSOR-COMP.(DISCHARGE TEMP)	1	CWA50C2576	O
	28	CABINET REAR PLATE-COMPLETE	1	ACXE02-02020A	
	29	CONTROL BOARD CASING	1	CWH10K1228	
	30	SENSOR-COMP.(DEFROST TEMP)	1	CWA50C2577	O
	31	TERMINAL BOARD ASS'Y(1,2,3,4,5)	1	CWA28K1240	O
	32	TERMINAL BOARD ASS'Y(U,V,W)	1	CWA28K1335	O
	38	ELECTRONIC CO.(NOISE FILTER)	1	CWA747735	O
	44	ELECTRONIC CONTROLLER (MAIN)	1	ACXA73C40860R	O
	46	REACTOR - MAIN	3	G0C213J00001	O
	50	FAN MOTOR BRACKET	1	CWD54K1024	
	51	SCREW-FAN MOTOR BRACKET	2	CWH551040J	
	52	FAN MOTOR(UPPER)	1	EHDS83LAC	O
	53	FAN MOTOR(LOWER)	1	EHDS83MAC	O
	54	SCREW-FAN MOTOR MOUNT	8	CWH551323	
	55	PROPELLER FAN ASSY	2	CWH00K1006	
	56	NUT	2	CWH561092	
	57	CABINET FRONT PLATE	1	CWE061098A	
	58	DISCHARGE GRILLE	2	CWE201073	O
	59	CABINET SIDE PLATE ASSY	1	CWE04K1023A	
	60	WIRE NET	1	CWD041069	
	61	CABINET TOP PLATE	1	CWE03C1105	
	62	ACCESSORY CO.(RUBBER CAP)	1	CWH82C1839	
	66	CABINET FRONT PLATE	1	CWE061274A	
	67	HANDLE	2	CWE161014	
	68	TUBE ASSY (CAP.TUBE)	1	CWT07K1742	
	70	EXPANSION VALVE (1)	1	CWB051049	O

SAFETY	REF. NO.	DESCRIPTION & NAME	QTY.	WH-MXC16H9E8	REMARK
	71	EXPANSION VALVE (2)	1	CWB051029	
	72	2-WAYS VALVE(LIQUID)	1	CWB021637	O
	73	V-COIL COMPLETE(2-WAY VALVE)	1	CWA43C2607	O
	74	V-COIL COMPLETE(BYPASS EXPANSION VALVE)	1	CWA43C2335	O
	75	ACCESSORY CO.(DRAIN ELBOW)	1	CWG87C900	
	76	HEATER	1	CWA341071	O
	78	SENSOR COMPLETE (BYPASS & EVA EXIT TEMP)	1	CWA50C3165	O
	80	SOUND PROOF MATERIAL	1	CWG302598	
	82	ELECTRO MAGNETIC SWITCH	1	K6C2AGA00002	O
	83	ELECTRO MAGNETIC SWITCH	1	K6C4E8A00001	O
	84	REACTOR - SUB	3	G0C353J00001	O
	85	PTC THERMISTORS	1	D4DDG1010001	O
	86	CAPACITOR	3	DS451605DPQB	O
	87	LEADWIRE COMPRESSOR	1	ACXA60C62280	
	88	SENSOR-COMPLETE (CN-TANK)	1	-	
	89	FLEXIBLE PIPE (L-TUBE)	1	CWH5850080	
	90	PACKING-L.TUBE	1	CWB81012	

**Note:**

- All parts are supplied from PAPAMY, Malaysia (Vendor Code: 00029488).
- "O" marked parts are recommended to be kept in stock.